

Read entire instructions thoroughly before starting. Installation should be performed only by qualified personnel. Observe all safety precautions when working beneath a vehicle. Always wear safety glasses for eye protection.

NOTE: This trailer hitch cannot be used in conjunction with the REAR TOW HOOK KIT.

TOOLS REQUIRED:

- Safety glasses
- Push-pin removal tool
- 13mm, 15mm, 18mm sockets
- Socket wrench
- Two metal measuring scales
- Marker
- Center punch
- 1/8", 7/16", 13/32" drill bits
- Drill motor
- De-burring tool
- Corrosion inhibitor
- Torque wrench

CONTENTS:

NOTE:

This trailer hitch kit cannot be used in conjunction with the rear tow hook kit.

Item	Qty.	Description
①	1	Hitch Assembly
②	2	Bolt & Cone washer Assy
③	2	Braces
④	4	Hex Flange Locknuts
⑤	1	4-Way Adaptor Kit (not shown)
⑥	1	Receiver Cover
⑦	6	Push-Pin Retainers
⑧	1	Installation Instructions

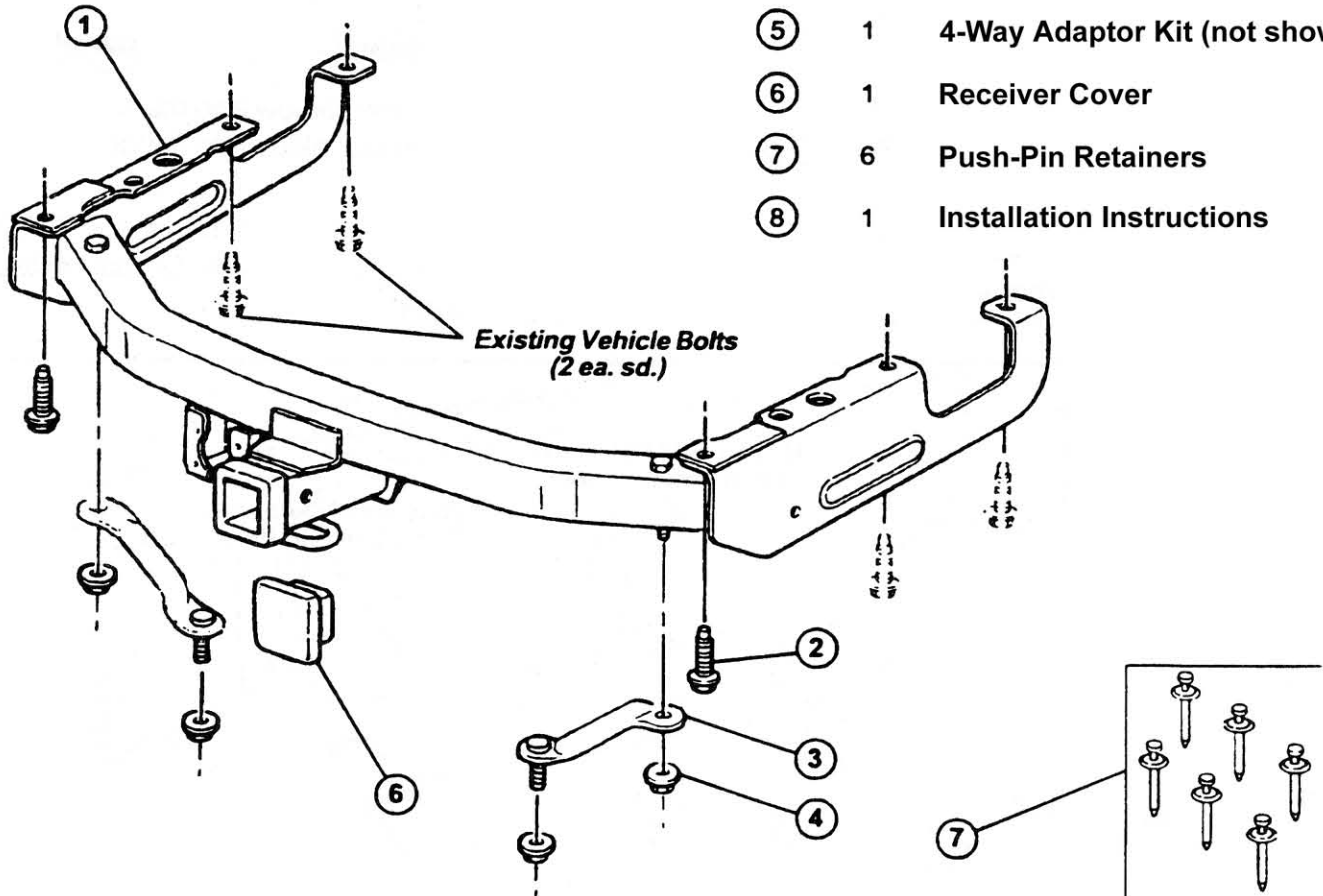

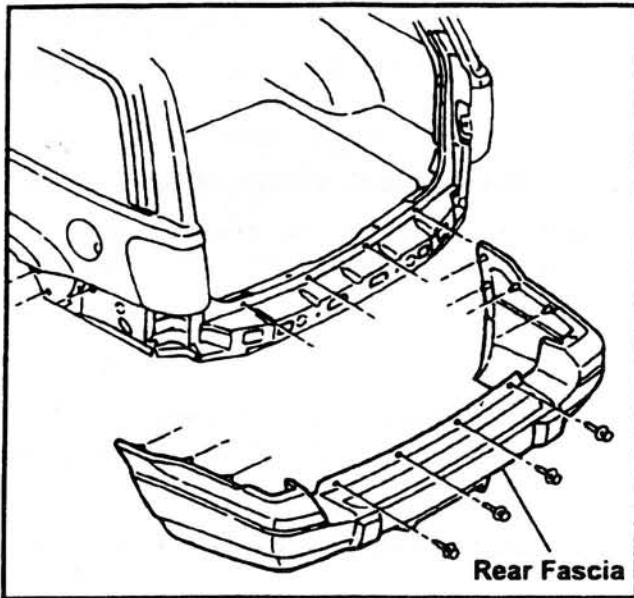

- 1) Using the proper fastener removal tool, remove the rear fascia.
- 2) **NOTE:** Fascia must be modified to install this hitch kit. Obtain the Mopar fascia bezel kit that matches the vehicle application. Install bezel to fascia using instructions supplied in the bezel kit.
- 3) Raise and secure the vehicle on a lift.

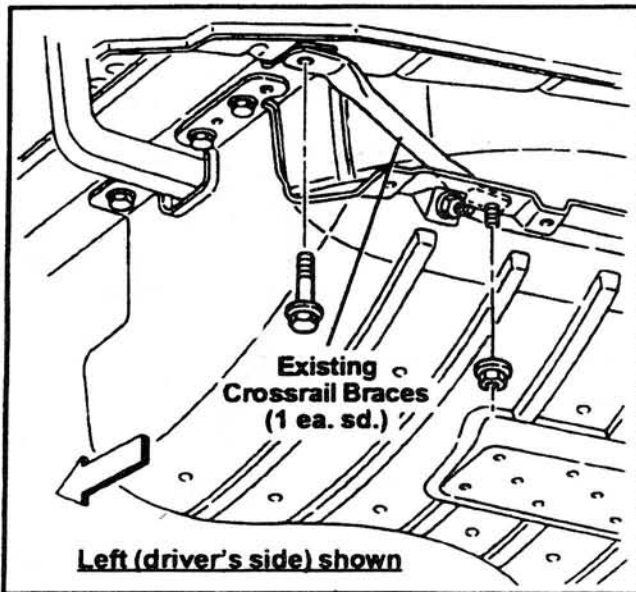

A – Vehicles Equipped with Rear Crossrail Braces:

- 4) Using 15mm and 18mm sockets, remove and discard the existing braces and fasteners.

B – Vehicles Not Equipped with Rear Crossrail Braces:

- 4) Measure as shown below and mark for drill hole locations in the rear skid plate flange.
- 5) Center punch, drill 1/8" pilot holes, then 7/16" mounting holes at your marks. De-burr holes and apply corrosion inhibitor.

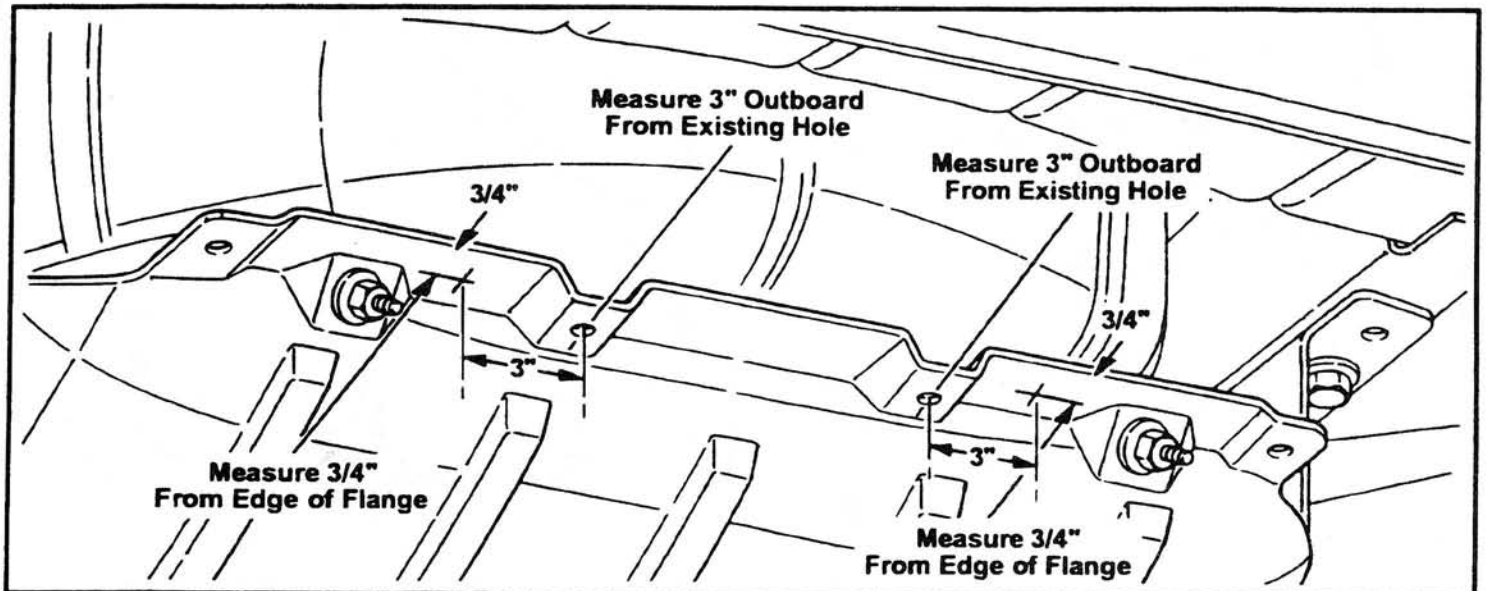

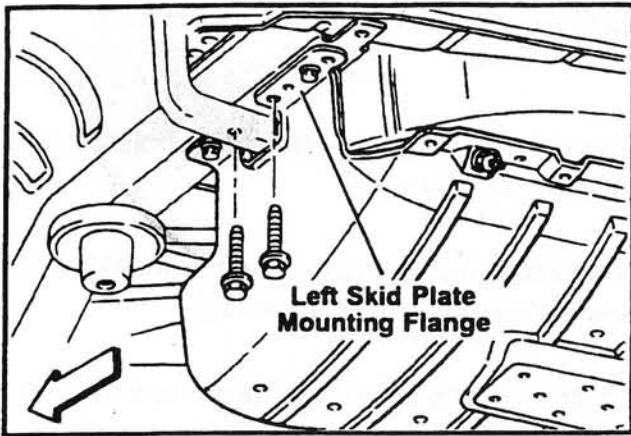

C – Remove Existing Skid Plate to Frame Rail Bolts:

- 1) Using an 18mm socket, remove only two bolts from the left (driver's side) skid plate mounting flange. Leave the two remaining bolts in place.
- 2) Save the removed bolts for re-use.

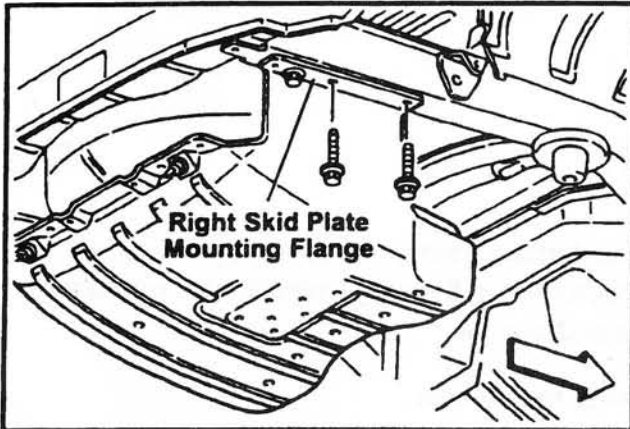

- 3) Using a 18mm socket, remove only two bolts from the right (passenger's side) skid plate mounting flange. Leave the one remaining bolt in place.
- 4) Save the removed bolts for re-use.

D – Install the trailer hitch assembly:

- 1) With two service technicians, lift the hitch (Item 1) up to the vehicle.
- 2) Loosely install the four saved bolts and two supplied bolts (Item 2) as shown below.
- 3) Tighten all fasteners. Torque to 65 ft.-lbs. (± 5) (88.1 N·m).

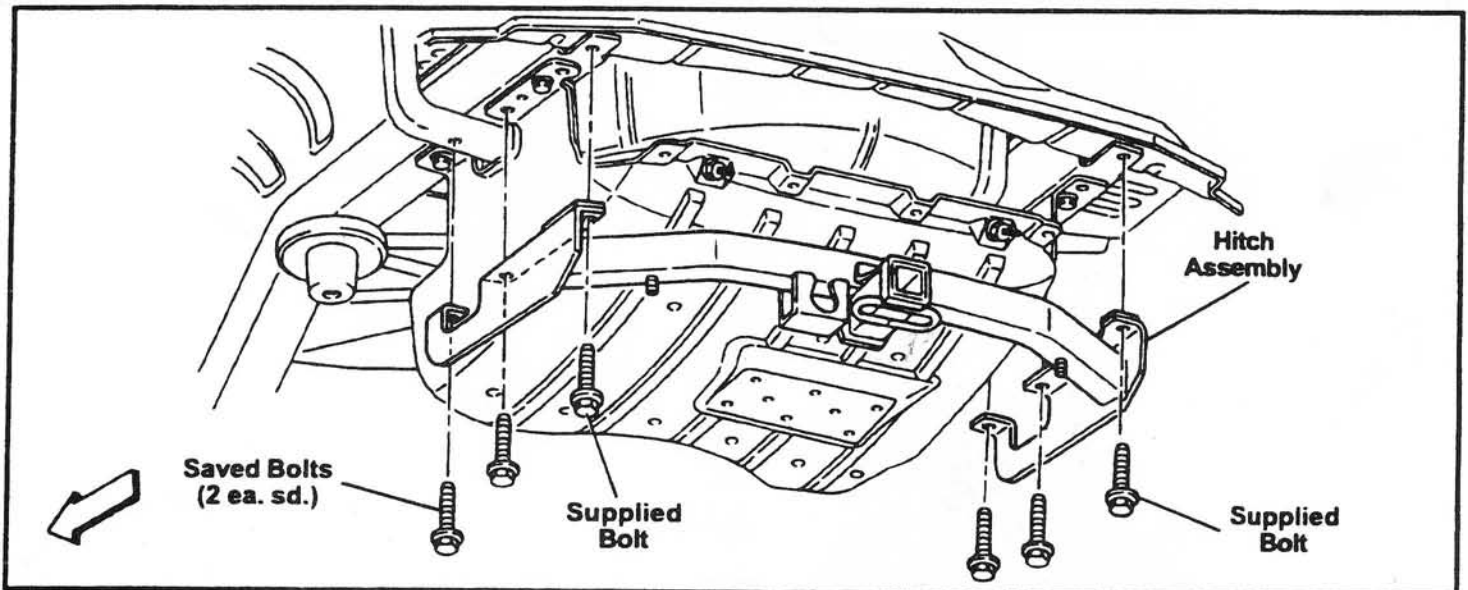

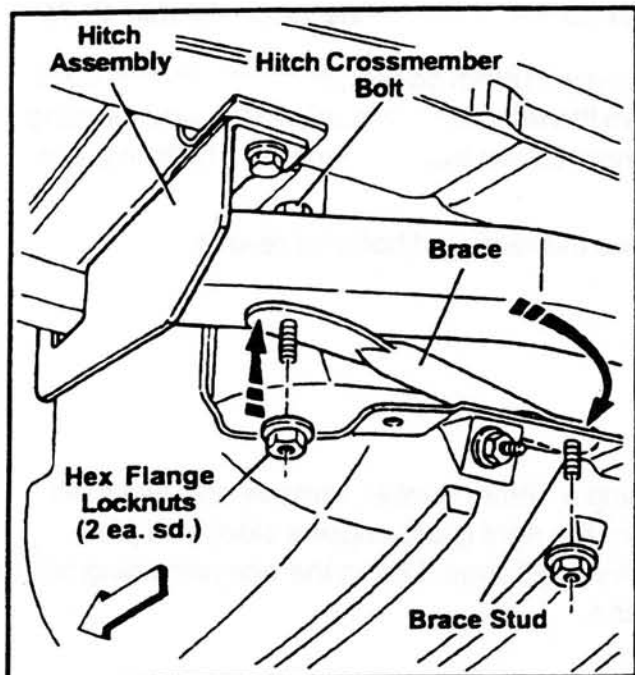

- 4) Position the braces (Item 3) onto the hitch crossbar bolts.
- 5) Swing the braces over to mounting holes in the rear skid plate flange.
- 6) Loosely install hex flange locknuts (Item 4) onto the braces studs and crossbar bolts.
- 7) Tighten all brace fasteners. Torque to 65 ft.-lbs. (± 5) (88.1 N·m).

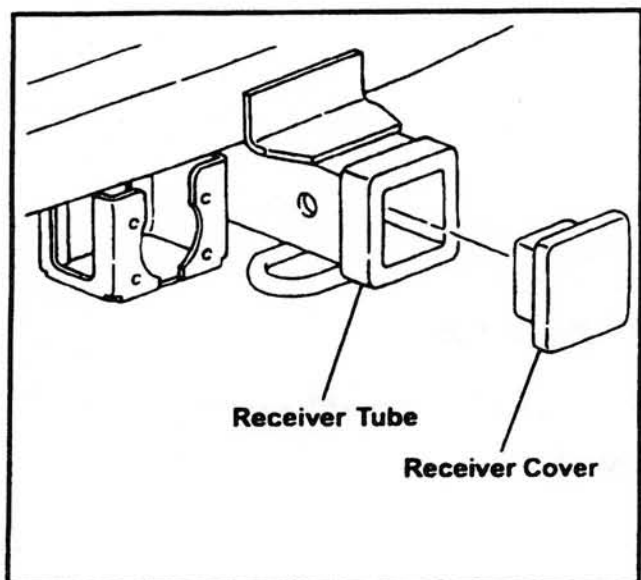

- 8) If customer desires, install 4-way trailer tow adaptor (Item 5) using instructions supplied in the adaptor kit.
- 9) Lower the vehicle.
- 10) Install receiver cover (Item 6) to the hitch receiver tube.
- 11) Using supplied push-pin retainers (Item 7) and any four undamaged retainers, re-install the modified rear fascia.
- 12) Supply customer with the operating instructions (Page 5 of 5).

OPERATING INSTRUCTIONS

MAXIMUM RECEIVER CAPACITY*

WHEN USED AS:	ENGINE	MAX. TRAILER WT. (LBS.)	MAX. TONGUE WT. (LBS.)
* WEIGHT DISTRIBUTING	8 CYL	6,500	750
	6 CYL	5,000	750
* WEIGHT CARRYING	8 CYL	2000	200
	6 CYL		

* Consult vehicle owner's manual for specific towing capacity and trailer requirements.

CAUTION !

Do not exceed the recommended towing capacities. Failure to observe the recommended limits could result in hitch failure, deteriorated vehicle performance and control or vehicle overheating.

NOTE:

Check hitch frequently to make sure that all fasteners and trailer ball are tightened properly. A hitch or ball mount which has been damaged in any way should be removed and replaced before further use.

BALL MOUNT ADAPTOR AND BALL USAGE

For weight-carry applications up to 2,000 lbs. gross trailer weight, use Mopar ball mount adaptor 82200248 and approved Mopar trailer ball.

Use of this receiver as a weight distributing hitch requires obtaining equipment not available through Mopar. Contact your trailer dealer for assistance in buying a load-equalizing hitch compatible with your trailer.

CAUTION !

If the ball mount is stored inside the vehicle, place it in a secure area to prevent possible personal injury in the event of a sudden stop.

NOTE:

Make sure that the receiver cover is installed in the hitch receiver tube whenever the ball mount is not in use.